

Smart Start™

Starter Shingles

Smart Start™ shingles are made with our patented **NEX® Polymer Modified (SBS Rubberized) Asphalt**, an innovative technology that infuses rubber and plastic polymers to strengthen the asphalt core of the shingle for superior impact resistance, granule adhesion, all-weather resilience, and aging longevity.

Smart Start™ shingles are also sustainable. Upcycled polymers from used tires and plastic bags improve durability and aging resistance, while helping reduce landfill waste. *Sustainability without sacrificing performance.*

INSTALLED THIRD

When installing a complete 5-component system, starter shingles are installed third, after the underlayment, and prior to the field [roofing] shingles.

LARGER SIZE

Starter shingles extend up beyond the fastening point of the first row of field shingles, providing maximum protection against wind uplift and moisture migration.

NEX® RUBBERIZED ASPHALT
Asphalt core of shingle is rubberized with virgin synthetic rubber polymers (SBS) to enhance shingle strength, flexibility, and aging resistance.

UPCYCLED RUBBER & PLASTIC
Polymers from recycled rubber and plastic improve shingle durability while diverting used tires and plastic bags from the landfill.

TWO-IN-ONE

Starter shingles come designed to be split into two, full-size, code-compliant starters using a time-saving perforation.

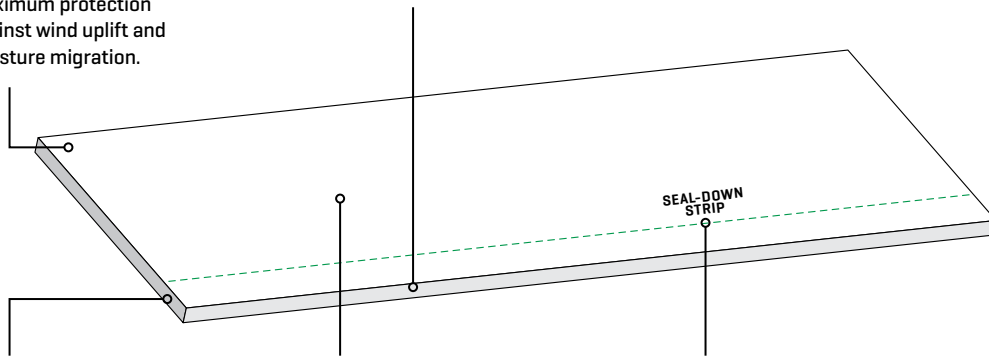

FIBERGLASS MAT
Provides structural reinforcement and tear strength.

ROOFING GRANULES
Natural mineral granules protect shingle from weather and UV aging. Superior granule adhesion.

POLYMER MODIFIED ADHESION
Synthetic rubber adhesive (SEBS) bonds provide exceptional seal-down and wind protection at the eave and rake edges of the roof.

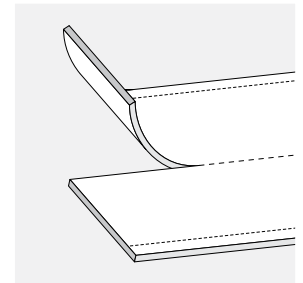

 Malarkey Industry Firsts

Test Compliance – ASTM D3462, ASTM D3161 Class F, and ASTM E108 Class A Fire Rating. Smart Start™ is eligible for expanded warranty coverages relative to its use as a single roofing accessory or in combination with others in a complete Malarkey roofing system. Installed separately, it carries a 10-year product warranty against manufacturing defects. For complete warranty information, please visit www.malarkeyroofing.com/warranties.

This version supersedes all previous versions. Rev. 05/23

www.malarkeyroofing.com
800-545-1191

MADE IN USA

 **HOLCIM**